

# NAVIGATOR - 2



## Description of Menu and Control of NAVIGATOR-2

### 1. Control of sensor and indication of position of telescope

**NAVIGATOR-2** (thereinafter **NAVI-2**) is an electronic device for measuring and indication of telescope's position (the site). NAVI-2 gets information about changes of telescope's position from sensors DSC. More info can be fined in:

*[/navi2\\_init\\_running\\_200407\\_e.pdf](#)*

and in:

*[/navi2\\_funct\\_parameter\\_200407\\_f.pdf](#)*

Senzores are placed on equatorial mount of telescope namely on axes of coordinate **Ra** (further in MENU: RA) and declination **Dec** (further in MENU: DE). Coordinate of telescope 's position is shown in two lines of LED display.

In the **left line of LED display** is shown **RA coordinate** in measures:

tens of hours	units of hours	tens of minutes	units of minutes	. tenths of minutes
---------------	----------------	-----------------	------------------	---------------------

In the **right line of LED display** is shown **DE coordinate** in this order:

sign	tens of degree	units of degree	tens of minutes	units of minutes	. tenths of minutes
------	----------------	-----------------	-----------------	------------------	---------------------

On red **LCD** display which has **8 alphanumeric character** he displays **information for user**.

The system is **controlled, parameter and data are entered** by pressing six buttons (by **Pic. 1**).

### 2. Bottoms

Bottoms are touch sensitive but the other bottoms do not work until the previous one is touched with the exception of interrupt request from DSC sensors and timing of axe RA. The pressed buttons is lighted by red color. Buttons don't work till you are not in MENU and then only buttons with function work. If you touch a button with no function, you will see only its name.

ESC	FUNC_X	FUNC_Y	POSITION	VALUE
				ENTER

**Pic. 1:** Position of buttons on NAVIGATOR-2

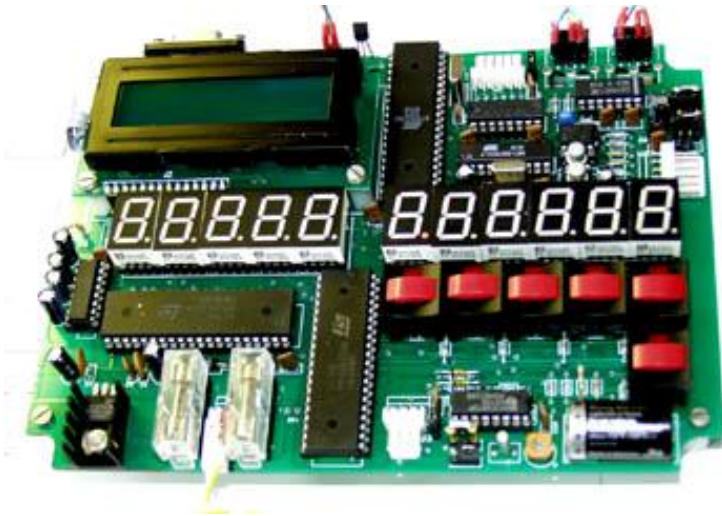

**Fig. 2:** NAVIGATOR-2: electronic device of sensor and indicator of telescope's position (indicator of site)

## Description of buttons and their function:

### ECS

By first touch you get main menu **MENU** or you leave menu **MENU**. After leaving menu you will see **MENU OFF**. By pressing ESC you delete any option. In next version of SW there will be a new function Back from actual Menu. In each part of menu it will be possible set where it will go back. This function does not work so far because first we need feedback from user who will have experience will the system and its needs.

### POSITION (POS button)

By pressing POS button we can change level of value during setting (button rotates from left to right). If the cursor is in the right, by next press it appears quite in the left.

### VALUE (VAL button)

VAL button has two functions:

- Menu choice **MENU**,
- Setting up a value of parameter on stated position in the straight direction (button rotates from left to right). If

there is a maximum by next pressing t turns to minimum (usually zero). Max. value depends on kind of setting number.

### ENTER (ENT button)

By pressing we confirm selection of menu **MENU** or selected value. The button has a peep function for using at night. After confirming of your choice or leave the menu.

**Remark:** Two buttons **FUNC\_X** and **FUNC\_Y** show accurate time **TIME** and date **DATE**.

### 3. MENU

NAVIGATOR-2 is controlled by buttons, two lines of display LED and one LCD display. On LCD you get information for user (for example position in menu) and LED display shows parameters. Left side shows RA or time, right side shows DE or date. After pressing ESC you get first enter of menu – Track **TRACK**. After confirming ENTER, actual parameters of RA and DE are shown on displays. Their changes are continuously measured by sensors and evaluated in system during entering data. Actual parameters if RA and DE are shown on display after leaving menu (if the needed function of NAVIGATOR-2 is turned on).

Menu **MENU** is selected to single sub menu according to the different functions that are implemented according to diagram on picture number 3. All levels in menu are cyclical, it means they repeat until any value is entered or ESC is pressed.

Reaction on ESC pressing can be programmed and therefore can differ in different sub-menus. A detailed instruction for each menu must be read in order to find out the proper reaction.

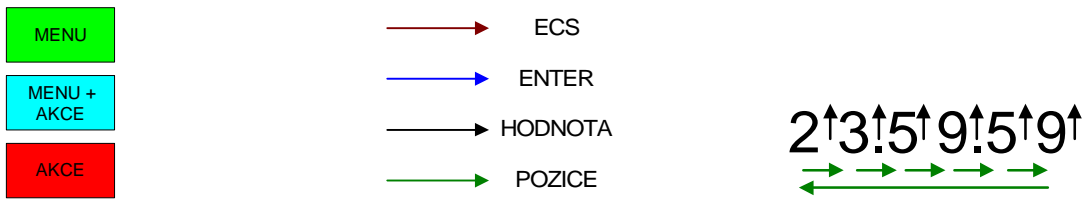

**Pic. 4** a. Colored marking of menu items      b. Colored marking of arrows      c. Colored marking of coordinate RA



**NAVIGATOR - 2 in operation**

**Flowchart of NAVIGATOR-2**

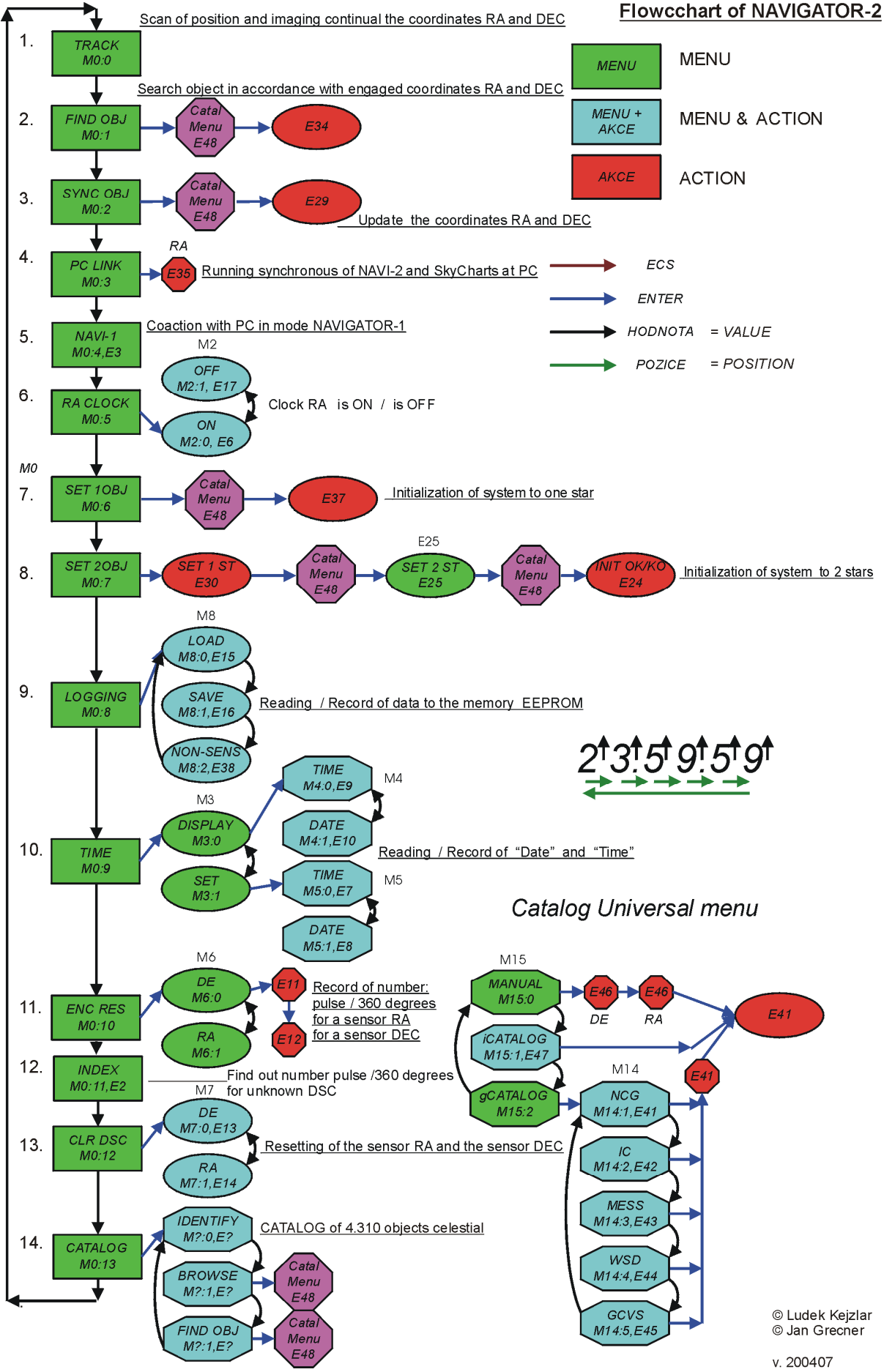

Picture num. 3 Flow Chart: **MENU** of function system NAVIGATOR-2

### Remark on picture number 3: Flow Chart

Scheme of rolling menu – Flow Chart in file `:/navi2_menu_flowchart_200407.pdf`

Black arrows sign pressing **VAL**, blue arrows pressing **ENTER**.

Colors of single items correspond to functions of menu parts

Stated menu scheme can be also fined in separate document `:/navi2_menu_flowchart_200407_e.pdf`

## 4. Description of FlowChart – rolled MENU

**MENU** items in the document are red as well as on **LCD** display. Their numeration matches of numbering in Flow Chart.

### 1. TRACK

**TRACK** mode is the basic mode of NAVI-2 where actual parameters of RA and DE are shown. This mode controls telescope's position – the site - with help of incremental rotated sensors DSC.

An appropriate setting (initialization) of system is needed for the right function (correct data on LCD and LED display). In case of inappropriate setting there are stated incorrect parameters of coordinates (BUT the relative distance between single celestials is correct).

### 2. FIND OBJ

**FIND OBJ** choice for finding an object.

When choosing **FIND OBJ** the user must set coordinates of sought object – this can be done either **MANUAL** or with help of **CATALOG**. After setting coordinates the system is switched to mode **FIND OBJ**.

**Ra^ Dec<** sign is shown on display. Arrows show direction that the telescope must be rotated in order to get in the appropriate position. Deviation between actual and required position is shown on LCD display. The telescope is in the appropriate position when there a zero parameter on the LED display. The repeated show of actual coordinates can be made by **TRACK** choice.

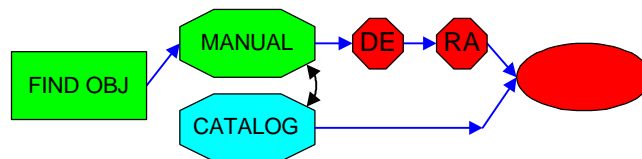

### 3. SYNC OBJ

This item works for correction (actualization) of settings of sensors RA and DE according to actual telescope's position (this function can be under certain circumstances used instead of **SET 2OBJ**).

This function enables setting of the right telescope's position by two choices **CATALOG** or **MANUAL**. Choices work in the same way as in menu **SET 1OBJ**. In contradistinction to function **SET 1OBJ** after setting of coordinates the counter control is proof-reading with regard to actual telescope's position (mainly DE).

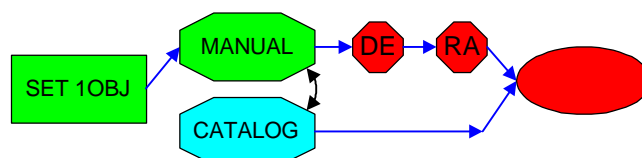

#### 4. **PC LINK**

The choice is experimental and determined for using Sky Charts in PC system NAVI-2 (including display RA and DE). It connected with choice **NAVI-1**.

For using PC LINK **PC LINK** you must follow these steps:

- (a) Initialization of NAVIGATOR-2 for one star **SET 1OBJ** or two stars **SET 2OBJ**,
- (b) Turn off timing RA **RA CLOCK** > **OFF** (it was automatically run by previous step)
- (c) Turn on function **NAVI-1**, in SkyChart connect COMx port, set 90°, and initialize system on two stars
- (d) Transfer on function **PC LINK** by the commands > **ESC** > **TRACK** > **FIND\_OBJ** > **SYNC\_OBJ** >
- (e) Turn on function **PC LINK**, whereas LED DE turn off > **RA/DEC** >
- (f) Manually insert actual position **RA** > **ENTER** > **DATA\_OUT** and go on
- (g) In SkyChart new synchronization on one or initialization on two stars and continue in scanning.

In the moment when **PC LINK** is chosen, the user is asked on **the actual value RA** which is set only manually. After inserting – whole system NAVIGATOR-2 is switch-over-to the mode in which pursue operation transformative valuables RA by only an “auxiliary variable” what hasn't an influence on valuables of counter RA (in case for example shift about 12h on transition DE over 90° or –90° and timing of RA). Auxiliary variable is using for display current value of RA on LED display. Timing of RA is startup automatically.

Function **PC LINK** is turned off in SW SkyCharts in PC in menu **Digital encoders** by pressing **Disconnect** and then setting up system NAVIGATOR-2 to a different mode f.ex. **TRACK**. After turning off the function RA timing is stopped. All other operations that change RA value are still working with NAVI-2.

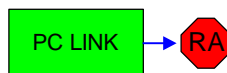

#### 5. **NAVI-1**

In this part of menu **NAVIGATOR-2 works together with PC**. System NAVIGATOR-2 works in this case as NAVIGATOR-1.

After confirming command **NAVI-1** port COMx - RS232 - is activated and NAVIGATOR-2 communicates in OURANOS protocol with personal computer. In PC is installed software SkyChart or (if you like) OURANOS. When active connection to PC all functions of system NAVIGATOR-2 works including RA axe if **RA CLOCK** is truned on. Only the commend **TRACK** can't be used because it is controlled by PC.

In NAVI-1 mode there is **NAVI-1** on display LCD and afterwards **DATA\_OUT**. Display LED does not show coordinates RA, DE, these are shown in SkyChart menu or OURANOS on PC. The only flashing the decimal point before coordinate DE indicates communication with PC via COMx.

**NAVI-1** mode is cancelled by turning into different mode f.ex. TRACK, INDEX, then communication between NAVIGATOR-2 and PC is cancelled. Function PC LINK is connected to this function.

## 6. RA CLOCK

In this MENU you can **control timing of RA axe**. After choosing you are offered sub menu **ON** that can be changed to **OFF**. Sub menu can be changed by key **VALUE (VAL)**. Choice of sub menu is done by **ENTER (ENT)**.

Switch-on of function **RA CLOCK** is important first after initialization of the system. Usually RA CLOCK is turned on/off automatically. There are situations when the observer needs to control this by himself. In principle RA CLOCK is turned on because the sky "rotates". If the telescope does not move then RA value changes. After turning on RA (by pressing **ON**) the counter RA adds in appropriate interval one "1" to coordinate RA for a change synchronous of rotation of Earth. Option **OFF** turns off this function.

### If function **PC LINK** is activated

- then **RA CLOCK** must be turned on / off manually. NAVIGATOR-2 can not recognized witch kind of software is used in PC and whether it needs or not activation of RA CLOCK.

- **RA CLOCK** If function RA CLOCK is activated, then parameter RA in NAVIGATOR-2 corresponds with parameter RA in SkyChart PC. In that case "1" - one - s no-adds directly to counter RA but to so-called an "auxiliary variable" .

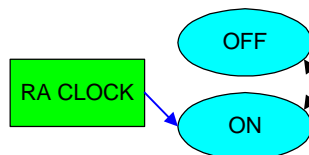

## 7. SET 1OBJ

Menu **SET 1OBJ** for setting basic value of coordinates RA and DE of single star on witch the telescope is pointed. Menu **SET 1OBJ** has two sub menus **CATALOG** and **MANUAL**, this can be select by button **VALUE (VAL)**. During moving to sub menu entry **MANUAL**, is offered first. In case of choosing **MANUAL**, the coordinates **DE** and **RA**. must be entered first in the following way

After entering menu **CATALOG** on LCD display the **name of first star** and RA and DE parameter are shown on LED display. By pressing button **POSITION** **constellation** and **visual magnitud** are showed. By next pressing **POSITION** button parameters are turned back. Other stars from catalog are chosen by pressing button **VALUE**. Chosen object is confirmed by pressing **ENTER**.

After entering coordinates are values un-normed according to set parameters DSC sensors and directly written in counters RA and DE. After pushing **ESC** button system moves in to the **MANUAL** mode and setting **DE**. value is offered. It helps in case that the object is not included in catalog. For leaving function **SET 1OBJ** press **ESC**. (Values "un-normed" means that normed values valid for maximum resolution of sensor 67535 pulse - they are corrected to reply for actual resolution of sensor for example 4000 pulse).

After choosing **MANUAL** the system offers automatically setting of **DE** item. From the counter is unloaded the actual value and write out on appropriate LED display. At the same time the digit with most high order is blinking. If you do not want to change the value **DE**, confirm it by key **ENTER** and only **RA** will be changed. From the counter is unloaded once again the actual value, it will be shown on actual LED display and at the same time the digit with most high order is blinking.

If you press **ESC** the setting will not be stopped. Registration of values RA to the counter implement in the moment of confirmation of coordinate **RA**. Value of the number during manual setting can be setted by key **VALUE**. After setting the right value next number can be sett by key **POSITION**.

After pressing key **POSITION** the the set number stops to flash and the new number is going to flash. As far as in this way come to digit lowest order, after next pressing of key **POSITION** the number is set.

**Coordinate RA** – number in form [hh:mm.1/10m] in range **00:00.0 do 23:59.9**. Only valid value can be inserted. At setting 2 on order of decades of hour take control of digit setting to order unit of time. If this digit unit of time is major than 3 then is automatically setting value on zero. Ten minutes and seconds is possible to adjust at intervals 0 – 5. Units of hours and minutes is possible to adjust in range 0 - 9.

**Coordinate DE** – value in form [degree : minuts : 1/10 minutes] in range from **-90:00.0 to +90:00.0**. Sign minus changes when 9 is reached. **When maximal value is reached, number is reseted.**

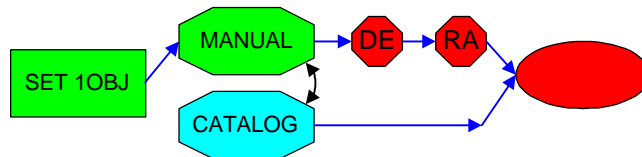

## 8. **SET 2 OBJ**

Item **SET 2 OBJ** provides **system's initialization on two stars**, with other words synchronization of telescope's mount with program of micro computer NAVIGATOR-2. This procedure must be fully followed in order to initialize thy system properly. After pointing two stars and setting their coordinates setting of montage and state of the counters is controlled and compared. If it's all in order announce a statement is **OK** to the contrary case announce a statement is **INIT KOx** where **x** is issue **1** or **2** or **3** indexing system state.

After choosing this item on LCD display there is a message **SET 1ST** that appeals the user to install the telescope on the first star. Value **RA** and **DE** are changed on LED displays, the value do not have to correspond with set coordinates(!). After turning the telescope in the direction of the chosen object **ENTER** must be pressed, then the system of setting coordinates must be chosen: **MANUAL** and **CATALOG**. In case of **MANUAL** choice you have to enter **DE** first and afterwards **RA**. The values are set in the same way as in **SET 1 OBJ**.

After entering menu **CATALOG** on LCD display the name of first star and **RA** and **DE** parameter are shown. By pressing button **POSITION** the **abbreviation of constellation** and **visual magnitude** are showed. By next pressing **POSITION** button parameters are turned back. Other stars from catalog are chosen by pressing button **VALUE**. Chosen object is confirmed by pressing **ENTER**.

Choice of another star from catalogue is made by key **VALUE**. After pressing this key the **NAME of STAR** is shown on the LCD and the coordinates of the star are shown on LED display. The catalogue is made circular, as menu. The choice of the object is confirmed by pressing **ENTER**.

After setting coordinates of the first star the **timing RA CLOCK** is activated. Parameter of counters is scanned at the moment of choosing the object (confirming RA), setting of the telescope can be made during setting coordinates. After pressing **ESC** setting of **DE** value is entered, for case that the user does not find the object in the catalogue.

After entering parameters of first star system asks to set telescope on second star ( **SET 2 ST** appears on LCD). Display shows **RA** and **DE** parameters that don't have to be accurate. After setting the second star you have to press key **ENTER**. The second star should not have the same coordinates as the first one, first of all coordinate **DE** must be different, otherwise the setting can be fail even if it ends successfully.

After setting up the second star you must enter its coordinates and confirm them. The value can be entered manually by **MANUAL** or from catalog **CATALOG**. Enter data in the same way as in case of the first star.

After setting and entering both stars the system **compares changes in encoder with entered values**. If differences are tolerable, system is set and an LCD appears **OK**. If difference is inadmissible display shows **INIT KOx**, **x** can be **1, 2, 3**.

**1: wrong RA, 2: wrong DE, 3: wrong RA and DE .**

Sources of disagreement: wrong setting of encoders' differentiation, wrong setting or entering wrong coordinators of stars or low accuracy of setting. Tolerance in comparison is 2 dc in quadrant mode of used DSC sensors.

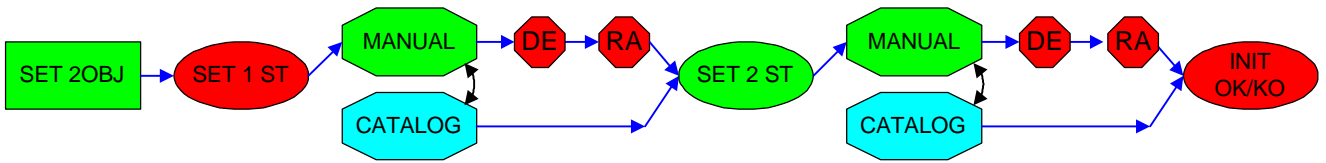

## 9. LOGGING

The item can be either **saved** or **set system NAVIGATOR-2** by submenu **LOAD** and **SAVE**.

By pressing **SAVE** the current system setting is saved to E-EPROM. The **parameter of encoders Ra and De, max and min of sensors** are saved. After choosing **LOAD** actual values are loaded into system.

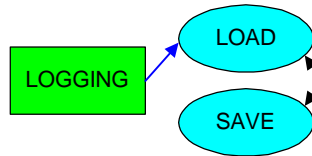

## 10. TIME

**TIME** menu item has two submenus and this item works with the real time. In the submenu there are two items **DISPLAY** and **SET**. Each of these items has its submenu **TIME** and **DATE**.

Function **DISPLAY** synchronizes second encoder in MCU with RTC timer. After choosing **TIME** > **DISPLAY** > **TIME** on display appears **WAIT** and system runs synchronization that lasts approx. one minute. And then the **current time is shown** in format **HH:MM:SS**. Closing Display function is made by transfer to function **TRACK**, not f. ex. to function LINK.

Function **SET** sets **TIME** or **DATE** from chip RTC. After choosing **TIME** > **SET** > **TIME** the current time from RTC is shown on LED display, the time is shown in format in **HH:MM**. The last number in seconds can not be set. The set numbers are checked for fail.

By choosing **TIME** > **SET** > **DATE** The actual date from RTC is shown on LED display, the date is shown in format in **date-month 00:00 ~ 99:99**. The last number in seconds can not be set. Parameters are not checked, invalid values can be entered. You must check the correctness by yourself. In case of wrong entry, the system is puzzled.

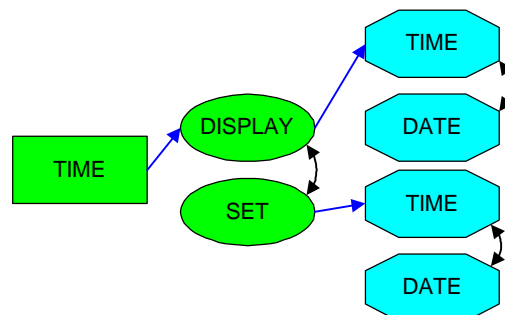

## 11. ENC RES

In this menu you can **set number of DSC pulses / 1 turn** (360°). In submenu there are two options RA and DE. By pressing button you get a current value on LED display. Numbers can be entered in **range 0 ~ 65535** for each axe separately. Correctness of numbers is not automatically set.

**Example:** encoder US Digital S2 has got 2000 pulses /360°. In quadrant mode generates 8000 pulses. This parameter can be entered in **ENC RES** mode as 08000.

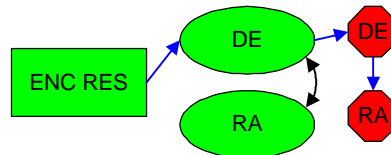

## 12. INDEX

In menu **INDEX** you can measure differentiation of unknown sensors DSC. You can find out a number of impulses of sensor by rotating 360°.

By confirming ENTER **nulls are written into counters of sensors Ra and De** and limits are set to maximum 65535. Display shows the current value in an decimal number of impulses generated in sensors.

To escape **INDEX** menu go to another menu (**TRACK**, **NAVI-1**).

Before testing sensors DSC we recommend to null counters in menu **CLR DSC**.

## 13. CLR DSC

**DSC** is abbreviation for **Digital Setting Circle**, here you can reset values of coordinates RA and DE in two submenu **RA** and **DE**.

Resetting coordinates RA and DE in fonction CLR DSC is assignet above all for menu **INDEX**. This function is able to however put together also for another purposes but no for initialization of system NAVIGATOR-2.

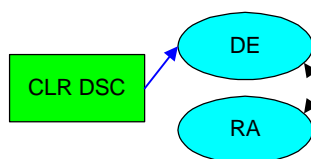

**NAVIGATOR - 2 in observatory**

## 14. CATALOG

New SW MENU for CATALOG of NAVIGATOR-2 is shown in Flow Chart in **Picture num. 3**

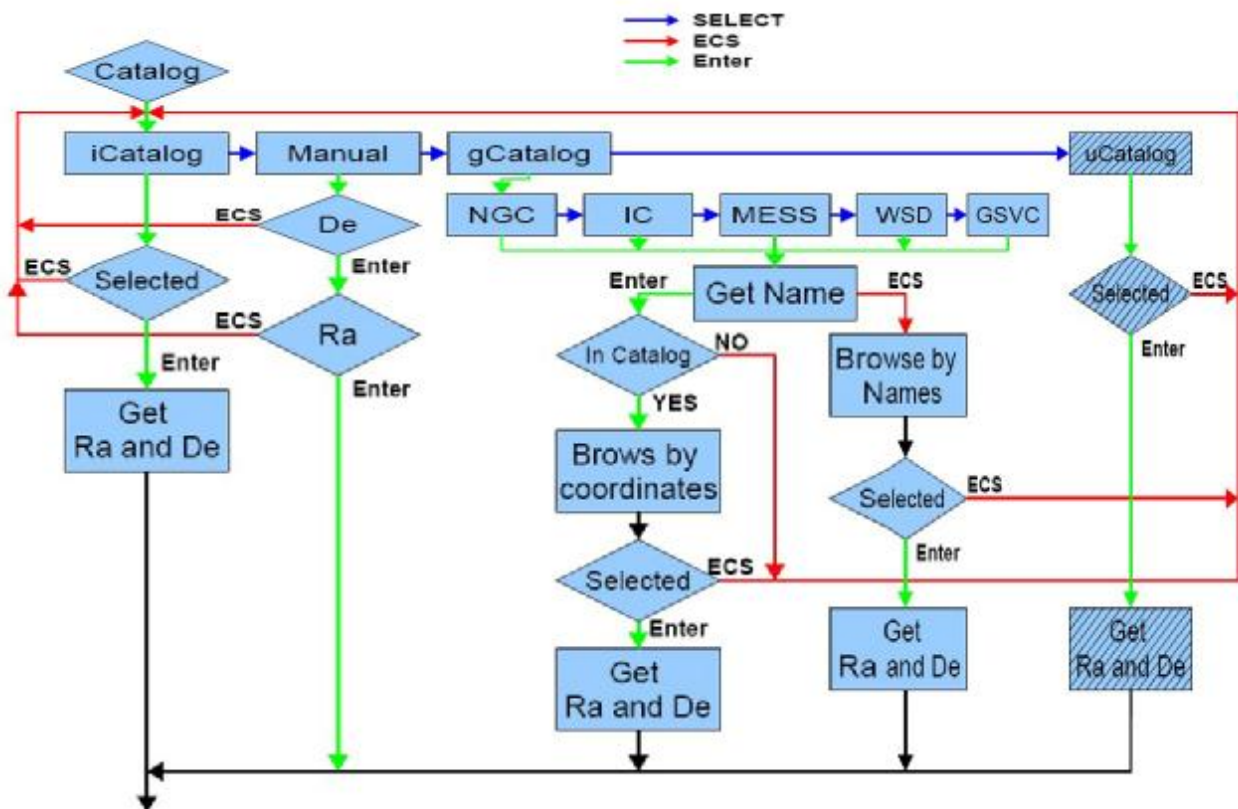

NAVIGATOR-2 Flow Chart of CATALOG

**Picture num. 4** CATALOG functions are shown in Flow Chart

**CATALOG** is new item in software menu for **NAVIGATOR-2**. development of software for NAVIGATOR-2 is finishing so we can spread software under version number b3. The advantage of CATALOG menu is combining all ways of using catalogs in previous SW versions.

**MANUAL** - **iGATALOG** - **gCATALOG** - **uCATALOG** are items from menu CATALOG.

Menu **uCATALOG** is prepared for future loading and saving from and to **EEPROM**

**MANUAL** is for manual use.

**iCATALOG** is the basic catalog for initialization of system NAVIGATOR-2 by single / two stars

**gCATALOG** is a new item that includes the main catalog. It includes sub catalogs:

**NGC** - **IC** - **MESS** - **WSD** - **GSVC**

After choosing correct catalog system NAVIGATOR-2 asks a **name of object**. You can enter the name directly or if you want to **choose object from list** press **ESC**.

**WSD** catalog, you must first insert the name and confirm (by **ENTER**) then insert numbers (and **ENTER**). If object is found system facilitates to browse in his environs according to RA coordinate. After choosing an object are coordinates used for next functions. By pressing **ESC** you can get on the beginning (choosing catalog)

**Toleration of objects coordinates accuracy** is **Ra +/- 1,5 sec** a **v De +/- 20 sec** to standart parameters. The oordinates stored in database are rounding in marked toleration. For records of objects in database and for mensuration of position of object with space-saving reason make use of standardized size 2 Byte.

**A number of objects** in menu **CATALOG**:

- **First 1200 objects** from catalogue **NGC/IC** (categorized by MAG)
- **All 110 objects** from **MESS catalogue**
- **3000 objects** from catalogues **WSD** and **GCVS** (categorized by MAG)

## 5. Conclusion

**Recapitulation of technical parameters OF system NAVIGATOR-2**

- High speed and accuracy of scanning positron of telescope.
- Brightness of LED and LCD displays can be changed according to observers need.
- Display enables reading coordinates from higher distances 2 - 3 m.
- Thanks on static driving LED display units there are not undesirable spurious signal troublesome CCD cameras.

This document is connected with latest software version n: 200407. Applicants can get this version for MCU AT89S8252 in HEX format.

Software for processor unit AT90S1200 is the same as in NAVIGATOR-1. To substitute IO AT90S1200 with ATtiny2313 can be done without changes HW. SW for MCU ATtiny2313 was tested and is disposal. Software for NAVIGATOR-2 is still in development.

This document will be continuously updated according to new software versions.

## 6. Authors of project NAVIGATOR-2



(c) Ján Grečner

and Luděk Kejzlar

*Translate:* Pavel Grečner

*File:* /navi2\_descript\_funct\_200407\_e.pdf *Date:* 1.11.2003 / 20.04.2007

At Prague of the day 20 April 20007.

**7. Application of NAVIGATOR - 2**



**NAVIGATOR - 2 in use**